

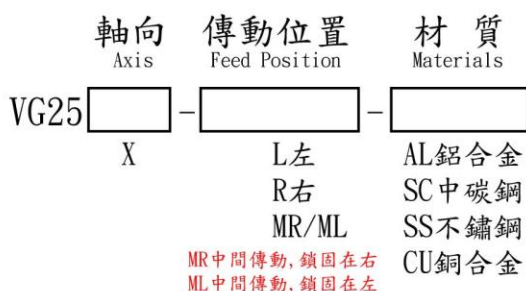

# 得豐實業有限公司

Dfwisdom Industrial CO., LTD

## VG25X 系列(單軸交叉滾子精密滑台)



## 規格特性 Specifications Characteristics

型號 Model	VG25X-L	VG25X-MR/ML	VG25X-R
枱面尺寸 Table Size	25 x 25 mm		
分厘卡測頭位置 Use Position	左 L	MR/ML	右 R
移動行程 Stroke	±3.2 mm		
移動真直度 Straightness	30 μm		
移動水平度 Motion Horizontal	30 μm		
移動俯仰度 Pitching	30"		
移動橫擺度 Yawing	30"		
檯面平面度 Horizontal	30 μm		
檯面平行度 Parallelism	30 μm		
水平耐荷重 Horizontal Allowable Loading	1 kg		
垂直耐荷重 Vertical Allowable Loading	0.5 kg		
最大保持力 Allowable Holding	4 kg		
重量 Weight	0.04kg		
材質 Material	鋁合金AL / 中碳鋼SC / 不鏽鋼SS / 銅合金CU		
表面處理 Surface Treatment	黑色鍍鉻 / 黑色陽極氧化 / 電鍍化學鍍		



得豐實業有限公司

Dfwisdom Industrial CO., LTD

VG25X 系列(單軸交叉滾子精密滑台)

VG25X-L DIMENSION

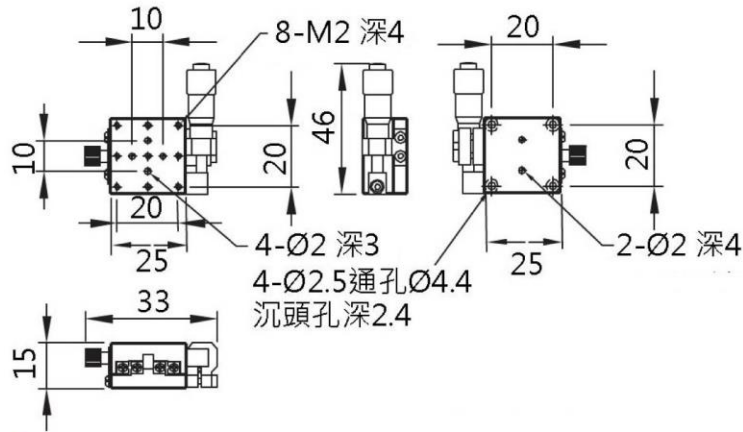

VG25X-MR DIMENSION

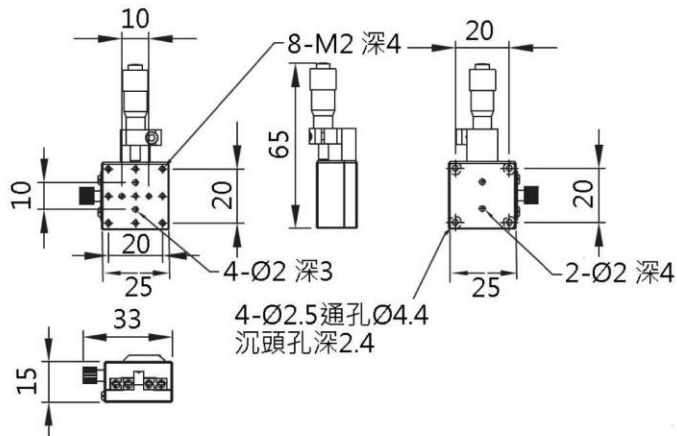

VG25X-R DIMENSION

