



# 得豐實業有限公司

Dfwisdom Industrial CO., LTD

## SMT-C 螺旋型/夾緊式/撓性聯軸器

Shaped Spirally / Clamp Type / Flexible Coupling



### 材質 | Material

鋁合金 Aluminum alloy

### 表面處理 | Surface Treatment

陽極處理 Anodizing standard white

### 特性 | Features

1. 一體成型
2. 零背隙
3. 螺旋式溝槽，可撓性特佳
4. 最適合譯馬器
5. 固定方式：夾緊式

型號 d1/孔徑 d2/孔徑  
Catalog Number Inside dia Inside dia

SMT-16C-  X

- One-body shape
- Zero backlash
- Spiral groove, great flexible performance
- Suitable for encoder
- Fixed mode: Clamp type

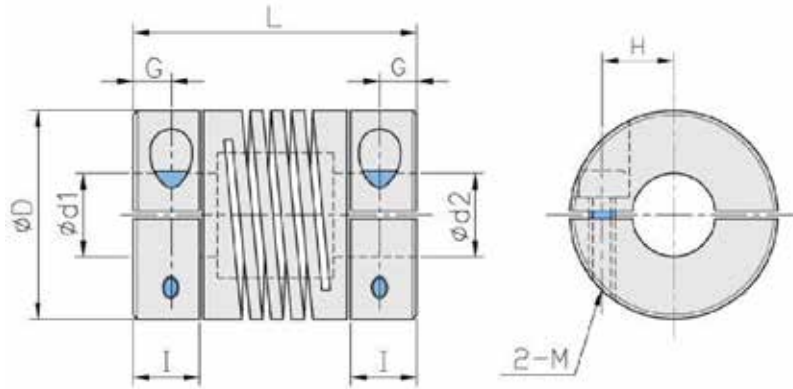

## 尺寸Dimension

單位 / Unit : mm

Catalog Number 型號	D	I	L	G	H	M	d1xd2 標準孔徑(H7)		Mass** 重量(g)
							Min	Max	
SMT-16C	16	6.2	23	2.5	5.0	M2.5	4	6.35	10
SMT-19C	19	6.5	23	3.0	5.6	M3.0	4	8.0	13
SMT-20C	20	7.5	26	3.0	5.7	M3.0	6	8.0	13
SMT-25C	25	8	31	4.0	7.5	M4.0	6	12.0	31

## 規格特性 Specifications Characteristics

單位 / Unit : mm

Catalog Number 型號	Ratad Torque 一般扭力 (N . m)	Max Torque 最大扭力 (N . m)	Max Rotational Frequency最高 回轉速(rpm/min)	Errors of Shaft End-Play容許 軸向位差(mm)	Errors of Eccentricity 容許偏心(mm)	Errors of Angularity 容許偏角(°)
SMT-16C	0.5	1.0	25000	± 0.25	0.25	5.0
SMT-19C	0.5	1.0	25000	± 0.25	0.25	5.0
SMT-20C	0.6	1.2	25000	± 0.25	0.25	5.0
SMT-25C	1.1	2.2	25000	± 0.25	0.25	5.0