



得豐實業有限公司

Dfwisdom Industrial CO., LTD

MRA-3A / 3B 角度感測器 (MAGNETIC SENSOR Analog Output)

- Long Life 高迴轉壽命: 1×10^9 cycles
- Output Type 輸出種類: 4 - 20 mA
- High Resolution 高解析值: $\pm 0.1\%$ FS
- Application 適合: 角度 Angle, 位置 Position, 張力 Tension, 速度 Speed



MRA-3A



MRA-3B

DIMENSION

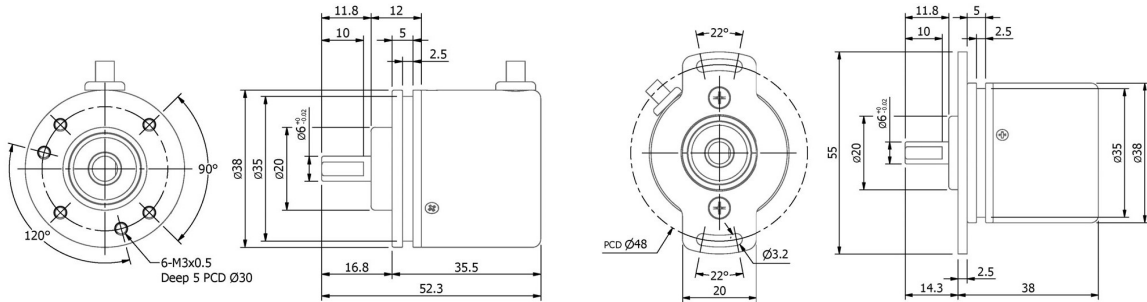

ELECTRICAL SPEC 電器規格

Power Supply 供應電源	[4-20 mA / 0-5V] DC 12 ~ 28V ; [0 - 10V] DC 15 ~ 28V
Output Type 輸出信號	[standard] 4 - 20 mA / 0 - 5V / 0 - 10V ; [option] 20 - 4 mA / 5 - 0V / 10 - 0V (decreasing)
Sensor Resolution 解析	12 bit (4096)
Response Time 輸出反應時間	20 ms (0 ~ 90 %)
Output Loading 輸出負載	(4 - 20 mA) $RL \leq 750 \Omega$, $RL : (V - 12) / 20 \text{ mA}$; (0 - 5V / 10V) $I_{out} \geq 1 \text{ mA}$, $RL \geq 10K \Omega$
Insulation Strength 耐壓強度 (Vrms)	1KV / min
Insulation Resistance 絕緣阻抗 (M Ω min)	100 M Ω / 500 Vdc
Temp. Coefficient 溫度係數 (ppm / $^{\circ}\text{C}$)	250 ppm / $^{\circ}\text{C}$

MECHANICAL SPEC 機械規格

Shaft Diameter 軸徑	6mm
Shaft Loading 軸荷重	Axial 軸向: 1Kg, Radial 徑向: 2Kg
Starting Torque (at 25 $^{\circ}\text{C}$) 起動轉矩	30 gf - cm or less
Mechanical Angle 機械迴轉角度	360 $^{\circ}$ Continuous 連續
Mechanical Life 機械迴轉壽命	1×10^9 cycles
Max. Speed 最大容許速度 (rpm)	60 rpm
Vibration 震動	10 - 55 Hz / 1.5 mm Vpp , 10 G (Max)
Shock 衝擊	20 g per 11 ms
Cable 電線	$\varnothing 4.5$, 1000 mm long
Weight 重量	$\leq 200\text{g}$

Connection 接線圖

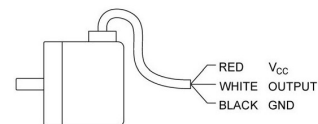

ENVIRONMENTAL SPEC 環境規格

Operating Temp. 操作溫度/濕度	-10 $^{\circ}\text{C}$ ~ 70 $^{\circ}\text{C}$, RH 35 % ~ 90 % (No Condensation)
Storage Temp. 儲存溫度	-20 $^{\circ}\text{C}$ ~ 80 $^{\circ}\text{C}$
Protection 保護等級	IP 50:dust proof

OUTPUT CURVE 輸出曲線

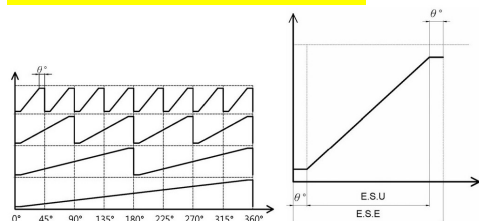

Specifications Model 規格 型號

MRA-3A 3B	Measuring Range 量測範圍	Signal Output 輸出信號	Signal Sequence 輸出方向
	04: angle 45 $^{\circ}$	420: 4-20 mA	*W: Reversed
	09: angle 90 $^{\circ}$	5V: 0-5V	
	18: angle 180 $^{\circ}$	10V: 0-10V	* OPTION
	36: angle 360 $^{\circ}$	(Standard Sequence)	

E.S.E.有效電子角度	45 $^{\circ}$	90 $^{\circ}$	180 $^{\circ}$	360 $^{\circ}$
E.S.U.使用電子角度	2 $^{\circ}$ ~ 43 $^{\circ}$	2 $^{\circ}$ ~ 88 $^{\circ}$	2 $^{\circ}$ ~ 178 $^{\circ}$	2 $^{\circ}$ ~ 358 $^{\circ}$
Nonlinear Error 非線性誤差	$\pm 0.50\%$ FS	$\pm 0.40\%$ FS	$\pm 0.40\%$ FS	$\pm 0.30\%$ FS
Repeatability Error 重複性誤差	$\pm 0.45\%$ FS	$\pm 0.25\%$ FS	$\pm 0.20\%$ FS	$\pm 0.15\%$ FS