



得豐實業有限公司

Df Wisdom Industrial CO., LTD

MLS-M 磁性拉線式感測器 (Linear Wire Transducer)



拉線類比感測器
 · 量測行程 1000 ~ 2000 mm
 * 0 - 10V 輸出
 * 4 - 20mA 輸出

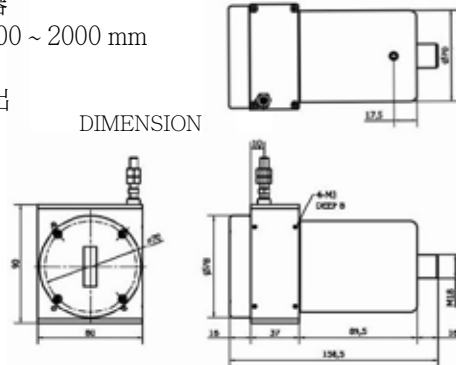

PRECISION ELECTRIC 0-10V AND CURRENT 4 - 20 MA SIGNAL OUTPUT
 SUITABLE FOR SHORT TO MEDIUM MEASUREMENT RANGE

ELECTRICAL SPEC 電器規格

| | |
|-------------------------------------|--|
| Full Stroke 量測行程 | 1000, 1250, 1500, 2000 |
| Sensor | Inductive Proximity Sensor |
| Output Signal Mode 輸出信號模式 | 4 - 20 mA (±0.8 mA) : 0 - 10V (±0.4V) |
| Resolution 解析 | 0.3 mm |
| Time Delay before availability | ≤ 50 msec |
| Input Power 供應電源 (U _B) | 15 - 30V |
| No - load supply current | ≤ 12 mA |
| Max. load at current output A2 | 500Ω (U _B = 15V) : 1KΩ (U _B = 30V) |

MECHANICAL SPEC 機械規格

| | |
|------------------------------|--|
| Wire Specification 線徑規格 | (stroke < 1250 mm) Diameter 0.6 mm SUS304 with nylon - coating (stroke < 1500 mm) Diameter 0.7 mm SUS304 with nylon - coating |
| Max . Travel Speed 最大往復速度 | 500 mm / sec. |
| Vibration 震動 | 10 Hz to 2000 Hz , 10 g |
| Cable 電線 | PUR 4 x 0.25 mm / 128 x ø 0.05 mm , cable length 2 m |
| Weight 重量 | < 1,300 g |
| Starting Torque on Spring 拉力 | (stroke 0 ~ 1250 mm) 600 g max. : (stroke over 1500 mm) 1000 g max |

ENVIRONMENTAL SPEC 環境規格

| | |
|------------------------------------|---------------|
| Operating Temp. / Humidity 操作溫度/濕度 | -25°C ~ 70°C, |
| Storage Temp. 儲存溫度 | -20°C ~ 80°C |
| Protection 保護等級 | IP 67 |

Specifications Model 規格 型號

HLS-M-

Measuring Range 量測行程

| |
|---------------|
| 10 : 1000 mm |
| 125 : 1250 mm |
| 15 : 1500 mm |
| 20 : 2000 mm |

Electrical Connection 接線圖

