



得豐實業有限公司

Df Wisdom Industrial CO., LTD

HTR-HN 中空軸心型 (ROTARY ENCODER HOLLOW SHAFT)

編碼器外徑：38 mm
 中空軸心 8 mm
 解析：5 ~ 3600 PPR
 安裝固定尺寸 PCD 40

DIMENSION

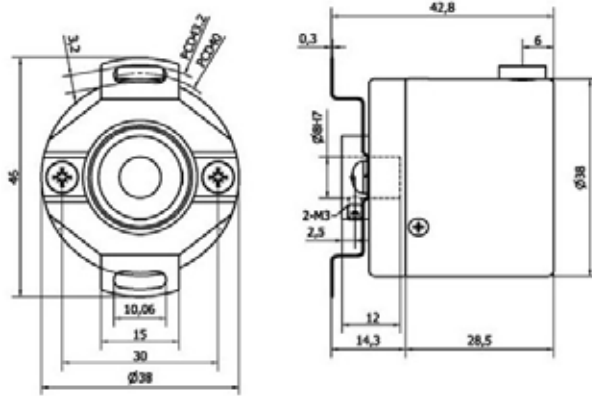

ELECTRICAL SPEC 電器規格

Detection System 檢測系統	Incremental 增量型
Output Wave 輸出波形	Square Wave 方波
Standard Number of Pulse Per Revolution 解析	5,10,50,100,200,300,360,400,500,600,900,1000,1024,
Output Phase 輸出相	ABZ phase
Electronics 電路特性	Push Pull 推挽式, Line Driver 差動式
Power Supply 供應電源	DC 5 ~ 26V
Current Consumption 消耗電流	≤60mA
Output Capacity 輸出容量	Sync. Current : 20mA, Residual Voltage : 0.5V or less
Max. Response 最大響應頻率	10K Hz ~ 100K Hz
Phase Different 相位差	A, B phase different 90° ± 45° (T/4 ± T/8), Z phase T ± T/2
Wave Form Rise / Fall 波形上下時間	2 μs or less
Polarity 極性保護	Against Reverse Protection

MECHANICAL SPEC 機械規格

Hollow Shaft Diameter 軸徑	8 mm
Shaft Loading 軸荷重	(5 ~ 1024 PPR) Axial 軸向 : 1 kg, Radial 徑向 : 2 kg (over 1024 PPR) Axial 軸向 : 0.5 Kg, Radial 徑向 : 1 Kg
Starting Torque (at 25°C) 起動轉矩	30 gf-cm or less
Max. Speed 最大機械容許轉速	6000 rpm
Vibration 震動	Max. 10 g (10 ± 1.500 Hz)
Shock 衝擊	20 g per 11 ms
Cable 電線	∅ 4.5, 1000 mm long
Weight 重量	≤ 200g

ENVIRONMENTAL SPEC 環境規格

Operating Temp./ Humidity 操作溫度/濕度	0°C ~ 60°C, RH 35% ~ 90% (No Condensation)
Storage Temp. 儲存溫度	-20°C ~ 70°C
Protection 保護等級	IP50 : Dust Proof

Specifications Model 規格 型號

HTR-HN - 8 -	<input type="text"/>	A -	<input type="text"/>
	Pulse / Revolution		Electronics
	解析		電路特性
	5,10,50,100,200,300,360,400,		P : Push Pull
	500,600,900,1000,1024,1200,		H : Line Driver
	1500,1800,2000,2048,2500,		C : NPN Open Collector
	3600		V : NPN Voltage