



得豐實業有限公司

Df Wisdom Industrial CO., LTD

HTR-HM 中空軸心型 (ROTARY ENCODER HOLLOW SHAFT)

編碼器外徑：60 mm
 中空軸心 12 / 15 mm
 解析：5 ~ 2500 PPR
 安裝固定尺寸 PCD 70.5



DIMENSION

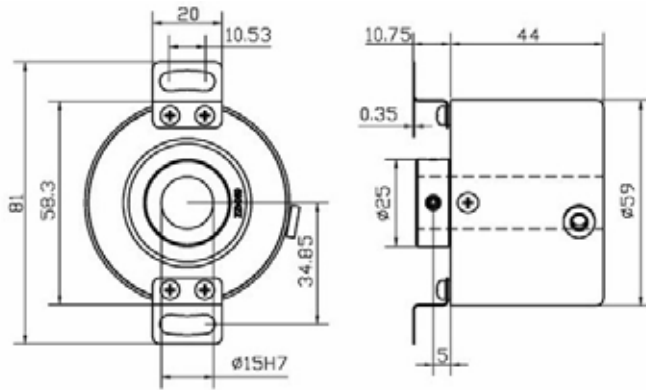

ELECTRICAL SPEC 電器規格

Detection System 檢測系統	Incremental 增量型
Output Wave 輸出波形	Square Wave 方波
Standard Number of Pulse Per Revolution 解析	5,10,20,30,40,50,60,80,100,120,150,180,200,250,300,360,400,500,600,720,800,900,1000,1024,2000,2500
Output Phase 輸出相	ABZ phase
Electronics 電路特性	Push Pull 推挽式, Line Driver 差動式
Power Supply 供應電源	DC 5 ~ 26V
Current Consumption 消耗電流	≤60mA
Output Capacity 輸出容量	Sync. Current : 20mA, Residual Voltage : 0.5V or less
Max. Response 最大響應頻率	10K Hz ~ 100K Hz
Phase Different 相位差	A, B phase different 90° ±45° (T/4±T/8), Z phase T±T/2
Wave Form Rise / Fall 波形上下時間	2 μs or less
Polarity 極性保護	Against Reverse Protection

MECHANICAL SPEC 機械規格

Hollow Shaft Diameter 軸徑	12, 15 mm
Shaft Loading 軸荷重	(60 ~ 1024 PPR) Axial 軸向 : 3 kg, Radial 徑向 : 5 kg (over 1024 PPR) Axial 軸向 : 2 Kg, Radial 徑向 : 4 Kg
Starting Torque (at 25°C) 起動轉矩	≤600 gf-cm
Max. Speed 最大機械容許轉速	6000 rpm
Vibration 震動	10 g (10 ±1.500 Hz)
Shock 衝擊	20 g per 11 ms
Cable 電線	ø5.4, 100 cm long
Weight 重量	≤450g

ENVIRONMENTAL SPEC 環境規格

Operating Temp./ Humidity 操作溫度/濕度	-10°C ~ 60°C, RH 35% ~ 90% (No Condensation)
Storage Temp. 儲存溫度	-20°C ~ 80°C
Protection 保護等級	IP50 : Dust Proof

Specifications Model 規格 型號

HTR-HM - [] - [] A - []		
Hole Size 中空軸徑	Pulse / Revolution 解析	Electronics 電路特性
12 : ø12	5,10,20,30,40,50,60,80,100,	P : Push Pull
15 : ø15	120,150,180,200,250,300,360	H : Line Driver
	400,500,600,720,800,900,1000	C : NPN Open Collector
	1024,2000,2500	V : NPN Voltage