



# 得豐實業有限公司

## Dfwisdom Industrial CO., LTD

### HTR-HJ-10 中空軸心型 (ROTARY ENCODER HOLLOW SHAFT)

Thru - Hub Diameter 10 mm

#### DIMENSION

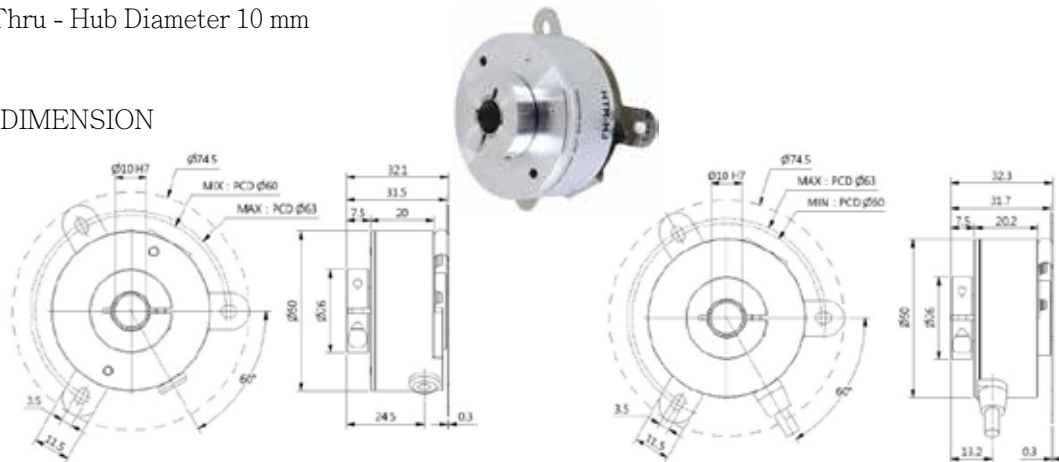

NPN Voltage / NPN Open Collector

Push Pull

#### ELECTRICAL SPEC 電器規格

Detection System 檢測系統	Incremental 增量型
Output Wave 輸出波形	Square Wave 方波
Standard Number of Pulse Per Revolution 解析	10, 100
Output Phase 輸出相	ABZ phase
Electronics 電路特性	NPN Voltage 電壓型, NPN Open Collector 電流型, Push Pull 推挽式
Power Supply 供應電源	DC 5 ~ 26V
Current Consumption 消耗電流	≤60mA
Output Capacity 輸出容量	Sync. Current : 20mA, Residual Voltage : 0.5V or less
Max. Response 最大響應頻率	10K Hz
Phase Different 相位差	A, B phase different 90° ±45° (T/4 ± T/8), Z phase T ± T/2
Wave Form Rise / Fall 波形上下時間	2 μs or less
Polarity 極性保護	Against Reverse Protection

#### MECHANICAL SPEC 機械規格

Hollow Shaft Diameter 軸徑	10 mm
Shaft Loading 軸荷重	Axial 軸向 : 1 kg, Radial 徑向 : 2 kg
Starting Torque(at 25°C) 起動轉矩	30 gf-cm or less
Max. Speed 最大機械容許轉速	6000 rpm
Vibration 震動	10 - 55 Hz / 1.5 mm Vpp. 10 G( Max. )
Shock 衝擊	20 g per 11 ms
Cable 電線	∅4.5, 1000 mm long
Weight 重量	≤200g

#### ENVIRONMENTAL SPEC 環境規格

Operating Temp./ Humidity 操作溫度/濕度	0°C ~ 60°C, RH 35% ~ 90% (No Condensation)
Storage Temp. 儲存溫度	-20°C ~ 70°C
Protection 保護等級	IP50 : Dust Proof

#### Specifications Model 規格 型號

HTR-HJ - 10 -	<input type="text"/>	A-	<input type="text"/>
	Pulse / Revolution 解析		Electronics 電路特性
	10, 100		V : NPN Voltage C : NPN Open Collector P : Push Pull