



得豐實業有限公司

Df Wisdom Industrial CO., LTD

HTR-HE 中空軸心型(超高解析) Hollow Shaft High Resolution

編碼器外徑 : 170 mm High Resolution
 中空全貫穿軸心 : 60 mm Hollow Shaft Diameter 60 mm
 解析 : 9000 ~ 90000 PPR Line Driver
 PCD 160 / 4- ϕ 5.5 DC 5V and DC 8 ~ 26V

DIMENSION

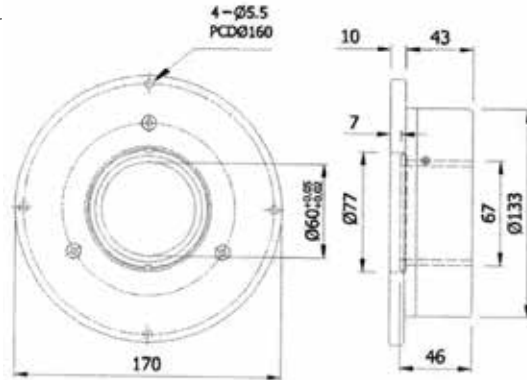

ELECTRICAL SPEC 電器規格

Detection System 檢測系統	Incremental 增量型
Output Wave 輸出波形	Square Wave 方波
Standard Number of Pulse Per Revolution 解析	9000, 18000, 36000, 72000, 90000
Accuracy 精度	± 15 arc.sec
Output Phase 輸出相	ABZ phase
Electronics 電路特性	Line Driver 差動式
Power Supply 供應電源	DC 5V and DC 8 ~ 26V
Current Consumption 消耗電流	≤ 60 mA
Output Capacity 輸出容量	Sync. Current : 20 mA, Residual Voltage : 0.5V or less
Max. Response 最大響應頻率	100K Hz
Phase Different 相位差	A, B phase different $90^\circ \pm 45^\circ$ (T/4 \pm T/8), Z phase T \pm T/2
Wave Form Rise / Fall 波形上下時間	1 μ s or less
Polanity 極性保護	Against Reverse Protection

MECHANICAL SPEC 機械規格

Hollow Shaft Diameter 軸徑	60 mm
Shaft Loading 軸荷重	Axial 軸向 : 1 kg, Radial 徑向 : 2 kg
Starting Torque(at 25°C) 起動轉矩	≤ 600 gf-cm
Max. Speed 最大機械容許轉速	1000 rpm
Vibration 震動	Max. 10 g
Shock 衝擊	20 g per 11 ms
Cable 電線	$\phi 5.4$, 1000 mm long
Weight 重量	≤ 1800 g

ENVIRONMENTAL SPEC 環境規格

Operating Temp./ Humidity 操作溫度/濕度	0°C ~ 60°C, RH 35% ~ 90% (No Condensation)
Storage Temp. 儲存溫度	-20°C ~ 80°C
Protection 保護等級	IP 50:dust proof

Specifications Model 規格 型號

HTR-HE-60- A -

Pulse per Revolution 解析	Electronics 電路特性
9000, 18000, 36000	L : Line Driver
72000, 90000	5Vdc
	H : Line Driver
	8 - 26Vdc