



得豐實業有限公司

Df Wisdom Industrial CO., LTD

HPN-6D 重載軸心型 (HEAVY DUTY)

編碼器外徑：60 mm
 軸心外徑：15 mm
 解析：5 ~ 5000 PPR
 PCD 56 / 4- ϕ 5.5



DIMENSION

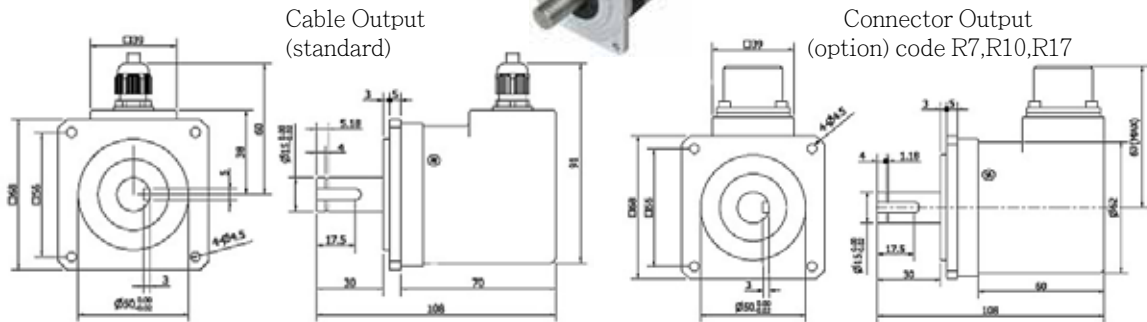

ELECTRICAL SPEC 電器規格

Detection System 檢測系統	Incremental 增量型
Output Wave 輸出波形	Square Wave 方波
Standard Number of Pulse Per Revolution 解析	5,10,20,30,40,50,60,80,100,120,150,180,200,250,300,360,400,500,600,720,800,900,1000,1024,1800,2000,2048,2500,3000,3600,4000,4096,5000
Output Phase 輸出相	ABZ phase
Electronics 電路特性	Push Pull 推挽式, Line Driver 差動式
Power Supply 供應電源	DC 5 ~ 26V
Current Consumption 消耗電流	$\leq 60\text{mA}$
Output Capacity 輸出容量	Sync. Current : 20mA, Residual Voltage : 0.5V or less
Max. Response 最大響應頻率	10K Hz ~ 100K Hz
Phase Different 相位差	A, B phase different $90^\circ \pm 45^\circ$ (T/4 \pm T/8), Z phase T \pm T/2
Wave Form Rise / Fall 波形上下時間	2 μ s or less
Polarity 極性保護	Against Reverse Protection

MECHANICAL SPEC 機械規格

Shaft Diameter 軸徑	15 mm
Shaft Loading 軸荷重	(10 ~ 1000 PPR) Axial 軸向 : 5 kg, Radial 徑向 : 10 kg (over 1000 PPR) Axial 軸向 : 3 Kg, Radial 徑向 : 6 Kg
Starting Torque(at 25°C) 起動轉矩	Without shaft seal 600 gf-cm or less
Max. Speed 最大機械容許轉速	2000 rpm for IP 65
Vibration 震動	10 g (10 \pm 1,500 Hz)
Shock 衝擊	20 g per 11 ms
Cable 電線	ϕ 5.4, 100 cm long
Weight 重量	$\leq 550\text{g}$

ENVIRONMENTAL SPEC 環境規格

Operating Temp./ Humidity 操作溫度/濕度	-10°C ~ 60°C, RH 35 % ~ 90 % (No Condensation)
Storage Temp. 儲存溫度	-20°C ~ 80°C
Protection 保護等級	IP 65 (option): with Shaft Seal

Specifications Model 規格 型號

HPN-6D - <input type="text"/>	A - <input type="text"/>	- <input type="text"/>
Pulse per Revolution 解析	Electronics 電路特性	Connector 連接器
5,10,20,30,40,50,60,80,100,120,150,180,200,250,300,360,400,500,600,720,800,900,1000,1024,1800,2000,2048,2500,3000,3600,4000,4096,5000	P : Push Pull H : Line Driver	*R7 : Radial 7 pin male connector *R10 : Radial 10 pin male connector *R17 : Radial 17 pin male connector