



# 得豐實業有限公司

## Df Wisdom Industrial CO., LTD

### HPN-6B 重載軸心型 (HEAVY DUTY)

編碼器外徑：60 mm  
 軸心外徑：10 mm  
 解析：5 ~ 5000 PPR  
 PCD 52.4 / 4- $\varnothing$ 5.5



DIMENSION

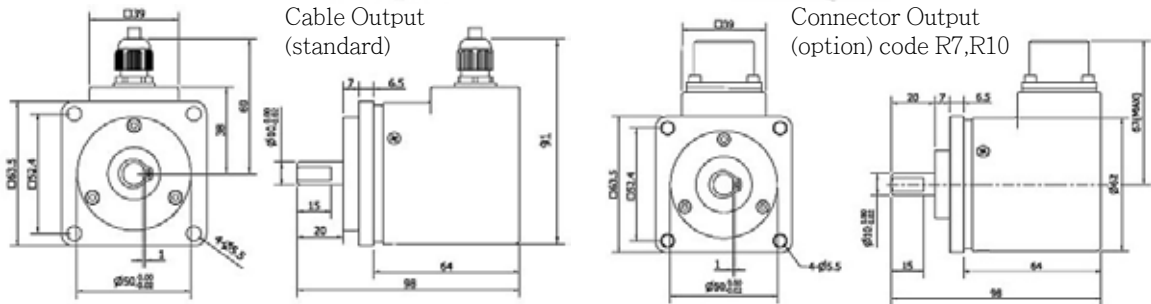

### ELECTRICAL SPEC 電器規格

Detection System 檢測系統	Incremental 增量型
Output Wave 輸出波形	Square Wave 方波
Standard Number of Pulse Per Revolution 解析	5,10,20,30,40,50,60,80,100,120,150,180,200,250,300,360,400,500,600,720,800,900,1000,1024,1800,2000,2048,2500,3000,3600,4000,4096,5000
Output Phase 輸出相	ABZ phase
Electronics 電路特性	Push Pull 推挽式, Line Driver 差動式
Power Supply 供應電源	DC 5 ~ 26V
Current Consumption 消耗電流	$\leq 60$ mA
Output Capacity 輸出容量	Sync. Current : 20mA, Residual Voltage : 0.5V or less
Max. Response 最大響應頻率	10K Hz ~ 100K Hz
Phase Different 相位差	A, B phase different $90^\circ \pm 45^\circ$ (T/4 $\pm$ T/8), Z phase T $\pm$ T/2
Wave Form Rise / Fall 波形上下時間	2 $\mu$ s or less
Polarity 極性保護	Against Reverse Protection

### MECHANICAL SPEC 機械規格

Shaft Diameter 軸徑	10 mm
Shaft Loading 軸荷重	(10 ~ 1000 PPR) Axial 軸向 : 5 kg, Radial 徑向 : 10 kg (over 1000 PPR) Axial 軸向 : 3 Kg, Radial 徑向 : 6 Kg
Starting Torque(at 25°C) 起動轉矩	Without shaft : 260 gf-cm or less With shaft seal : 400 gf-cm or less
Max. Speed 最大機械容許轉速	6000 rpm : 2000 rpm for IP 65
Vibration 震動	10 g (10 $\pm$ 1,500 Hz)
Shock 衝擊	20 g per 11 ms
Cable 電線	$\varnothing$ 5.4, 100 cm long
Weight 重量	$\leq 500$ g

### ENVIRONMENTAL SPEC 環境規格

Operating Temp./ Humidity 操作溫度/濕度	-10°C ~ 60°C, RH 35 % ~ 90 % (No Condensation)
Storage Temp. 儲存溫度	-20°C ~ 80°C
Protection 保護等級	IP 64:dust & dripping proof, IP 65(option) with Shaft Seal

### Specifications Model 規格 型號

HPN-6B-	<input type="text"/>	A-	<input type="text"/>	-	<input type="text"/>	-	<input type="text"/>
	Pulse per Revolution 解析		Electronics 電路特性		Connector 連接器		Protection 保護等級
	5,10,20,30,40,50,60,80,100,120, 150,180,200,250,300,360,400, 500,600,720,800,900,1000,1024, 1800,2000,2048,2500,3000,3600, 4000,4096,5000		P : Push Pull H : Line Driver		*R7 : Radial 7 pin male connector *R10 : Radial 10 pin male connector		* K1 : IP 65